



Sultan Qaboos University
College of Engineering
Department of Electrical and Computer Engineering

ECCE 3206
Digital Logic Design
Laboratory Manual

Version 1.0
Last Revision: 20-Aug-2005

Table of Contents

Preface	3
Experiment No. 1	4
Experiment No. 2	9
Experiment No. 3	11
Experiment No. 4	13
Experiment No. 5	17
Experiment No. 6	21
Appendix	24

Preface

This laboratory manual is a compilation of experiments conducted during laboratory sessions of the Digital Logic Design course over the past several years. During any given semester, it is not possible to conduct more than five or six experiments in a Lecture + Lab (2+2 hours) course therefore only six experiments have been included in this laboratory manual.

I would like to express my gratitude to all the instructors and laboratory staff of Digital Logic Design course who have collaborated with me, in one way or another, with the conduct and/or compilation of these experiments. These include:

Laboratory Instructors

Mr. Ahmad Al-Maashari and Mr. Mohammad Al-Nadabi

Technical Staff

Mr. Saleem Al-Rashdi and Mr. Sharif Al-Zadjali

Course Instructors

Dr. Ayman Elnaggar, Dr. Afaq Ahmad, and Dr. Mohammad Nazar

Any comments about this laboratory manual or suggestions to improve it may please be directed to me at my email address.

*Dr. Tariq Jamil
20-August-2005
tjamil@squ.edu.om*

Experiment No. 1

Introduction

This experiment is designed to get you familiarized with the two major parts of the digital laboratory: implementation and simulation. In this experiment, you are given “ready” functions to implement. In the subsequent experiments, you will be asked to design your own circuits so that they perform certain tasks and then simulate them.

(1) Familiarize yourself with the following equipment (*with the help of a lab assistant*):

- Bread Board
- Power Supply
- Leads
- IC 74xx or 74LSxx
- Switches
- Base Panels A4 size
- LED displays
- Seven-Segment display
- IC-tester

(2) Pick any 2-input IC that performs a certain logic operation (e.g. 7400 = 2-INPUT-NAND, see appendix for datasheets of various 74xx family ICs). Place the IC on the breadboard as shown below, and connect the circuit as follows:

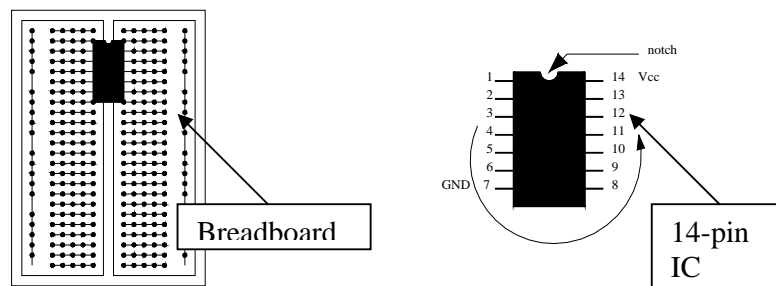

- + 5V (Vcc) to pin 14
- 0V (GND) to pin 7
- Switch 1 (input x) to pin 1
- Switch 2 (input y) to pin 2
- Pin 3 (output f) to LED

Fill in the following truth table:

input (x)	input (y)	output (f)
0	0	
0	1	
1	0	
1	1	

Lab assistant: _____

Refer to the IC-sheet provided in the appendix to answer the following questions:

Q1. What kind of logic operation does this chip perform?

Ans: _____

Q2. How many logic gates does this chip contain?

Ans: _____

(3) Select one more two-input 74xx family IC. Fill in the following table and write down the IC number and the function of that IC.

IC #: _____

Function: _____

input (x)	input (y)	output (f)
0	0	
0	1	
1	0	
1	1	

Lab assistant: _____

(4) Construct the truth tables of the following gates. Using IC-sheet given in the appendix, identify the ICs corresponding to these gates and verify their truth tables practically: In order to save on time, you can connect more than one gate at a time and then demonstrate it to the lab assistant.

(i) (a) **AND gate**

IC #: _____

input (x)	input (y)	output (f)
0	0	
0	1	
1	0	
1	1	

Lab assistant: _____

(b) Verify the truth table of an AND gate using LogicWorks software.

Lab assistant: _____

(ii) (a) **OR gate**

IC #: _____

input (x)	input (y)	output (f)
0	0	
0	1	
1	0	
1	1	

Lab assistant: _____

(b) Verify the truth table of an OR gate using LogicWorks software.

Lab assistant: _____

(iii) (a) NAND gate

IC #: _____

input (x)	input (y)	output (f)
0	0	
0	1	
1	0	
1	1	

Lab assistant: _____

(b) Verify the truth table of a NAND gate using LogicWorks software.

Lab assistant: _____

(iv) (a) NOR gate

IC #: _____

input (x)	input (y)	output (f)
0	0	
0	1	
1	0	
1	1	

Lab assistant: _____

(b) Verify the truth table of a NOR gate using LogicWorks software.

Lab assistant: _____

(v) (a) XOR gate

IC #: _____

input (x)	input (y)	output (f)
0	0	
0	1	
1	0	
1	1	

Lab assistant: _____

(b) Verify the truth table of an XOR gate using LogicWorks software.

Lab assistant: _____

(vi) (a) NOT gate

IC #: _____

input (x)	output (f)
0	
1	

Lab assistant: _____

(b) Verify the truth table of a NOT gate using LogicWorks software.

Lab assistant: _____

<=====END OF EXPERIMENT NO. 1=====>

(4) Draw logic diagram for the simplified expression of the function f .

(5) Simulate your logic diagram using LogicWorks software to verify that your design works correctly according to specifications. Show your simulation to the lab assistant.

Lab assistant: _____

(6) Implement your logic diagram using gates and get the circuit checked by the lab assistant.

Lab assistant: _____

<=====END OF EXPERIMENT NO. 2=====>

Experiment No. 3 Combinational Circuits Design, Simulation, and Implementation – II

In this experiment, you will design, simulate, and implement another simple digital circuit.

Binary Coded Decimal (BCD) numbers are 4-bit binary numbers that represent decimals less than ten (i.e. 0000, 0001, ..., 1001). Invalid BCD numbers are the 4-bit binary numbers that represent decimal greater than ten (i.e. 1010, 1011, ..., 1111).

(1) Construct the truth table for the valid BCD detector circuit. Assume that the 4-bit input binary number is w, x, y, z and the output is f .

(2) Obtain simplified expression for the output f in product-of-sums form using Kmap.

(3) Draw logic diagram for the simplified expression of the function f using NOR gates only.

(4) Simulate your logic diagram using LogicWorks software to verify that your design works correctly according to specifications. Show your simulation to the lab assistant.

Lab assistant: _____

(5) Implement your logic diagram using NOR gates and get the circuit checked by the lab assistant.

Lab assistant: _____

<=====END OF EXPERIMENT NO. 3=====>

Experiment No. 4

Adders

In this experiment, you will design, simulate, and implement various adder circuits.

A half-adder is a combinational circuit with two inputs (x, y) and two outputs (S, C_o): the sum and the carry. A full adder has three inputs (x, y, C_i) and two outputs (S, C_o). Full adders can be cascaded to carry out a multi-bit addition.

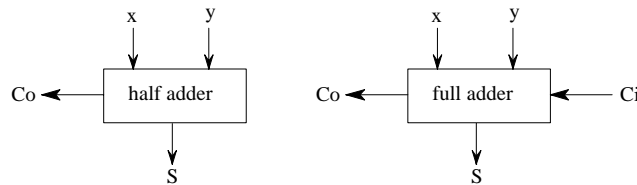

(1) Construct the truth table for a half-adder.

(2) Obtain simplified expressions for S and C_o using XOR and AND gates.

(3) Draw logic diagram of half-adder circuit.

(4) Simulate half-adder diagram using LogicWorks software. Show your simulation to the lab assistant.

Lab assistant: _____

(5) Implement half-adder circuit using gates and get it checked by the lab assistant.

Lab assistant: _____

(6) Construct a truth table for the full adder.

(7) Obtain simplified expressions for the outputs of a full-adder using Kmaps.

(8) Draw logic diagram of a full-adder circuit using half-adders and any additional gates (if needed).

(9) Simulate your diagram of the full-adder circuit using LogicWorks software. Show your simulation to the lab assistant.

Lab assistant: _____

(10) Implement full-adder circuit using gates and get it checked by the lab assistant.

Lab assistant: _____

(11) Build and test a 4-bit adder using 74LS283. Connect the output to a seven-segment-display and the carry to Decimal Point. Show your circuit to the lab assistant.

Lab assistant: _____

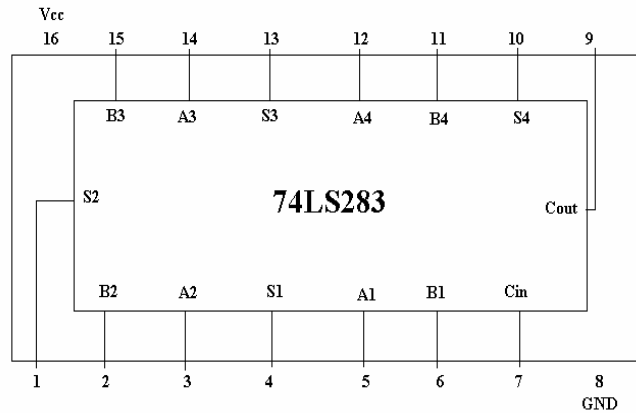

(12) Simulate the 4-bit adder using LogicWorks software. Use the part “Adder-4” from LogicWorks library. Show your simulation to the lab assistant.

Lab assistant: _____

<=====END OF EXPERIMENT NO. 4=====>

Experiment No. 5

Combinational Circuits Design, Simulation, and Implementation using Decoder and Multiplexer

In this experiment, you will design, simulate, and implement various combinational circuits using decoder and multiplexer.

A decoder is a combinational circuit having n -inputs and 2^n -outputs. The outputs of a decoder are all the minterms of the inputs. Thus, if the inputs to a decoder are C, B, and A (where C is the MSB), then the outputs Y0-Y7 are:

$$Y0 = \bar{C} \bar{B} \bar{A} = (000)_2$$

$$Y1 = \bar{C} \bar{B} A = (001)_2$$

.
.
.

$$Y7 = C B A = (111)_2$$

The 74LS138 is a 3x8 decoder IC but all of its outputs are inverted (active low).

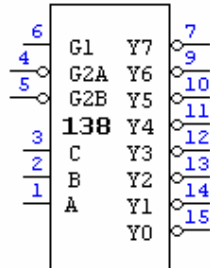

Remember to connect Pins 6 and 16 to Vcc & Pins 4, 5, and 8 to the common ground.

- (1) Using 74LS138 with additional logic, design a circuit with 3 inputs (C, B, A) and 3 outputs (Red, Green, Yellow) defined by:

$$R = \sum_{C,B,A} (0,1,2,3)$$

$$G = \sum_{C,B,A} (3,4,5,6)$$

$$Y = \sum_{C,B,A} (7)$$

Use only 74LS138 , 74LS10, 74LS00 & 74LS04 . For the outputs, use LEDs.

Show all your design steps in the space below:

(2) Simulate your design using LogicWorks software and show your simulation to the lab assistant.

Lab Assistant: _____

(3) Implement your design using ICs and show the working of your circuit to the lab assistant.

Lab Assistant: _____

(4) Design a circuit for the function $F(A, B, C) = \sum(2, 4, 5, 7)$ using a Multiplexer. Shown below is the **74LS153 Multiplexer IC** which consists of two 4-to-1 multiplexers. Connect GA to ground to activate multiplexer A or GB to ground to activate multiplexer B in the IC. Use this chip with any additional ICs to design the circuit for the given function.

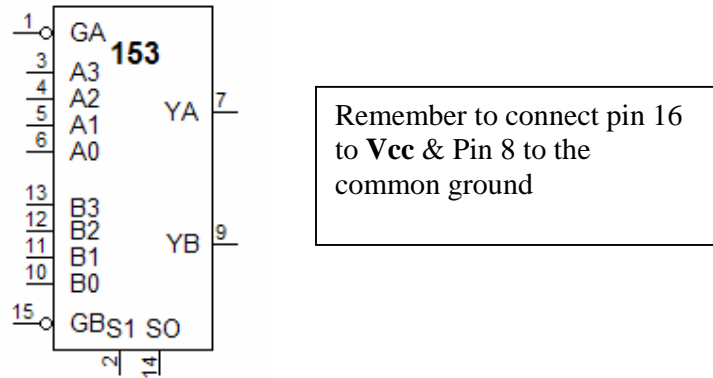

Show all your design steps in the space below:

(5) Simulate your design using LogicWorks software and show your simulation to the lab assistant.

Lab Assistant: _____

(3) Implement your design using ICs and show the working of your circuit to the lab assistant.

Lab Assistant: _____

<=====END OF EXPERIMENT NO. 5=====>

Experiment No. 6 Sequential Circuits Design, Simulation, and Implementation

In this experiment, you will design, simulate, and implement various sequential circuits.

(1) Design a 2-bit up-down counter using D-type flip-flops and **ONLY ONE** additional chip. Besides a common clock, there is one input, **U**. If **U** is **LOW**, the circuit counts **up** at each clock rising edge. If **U** is **HIGH**, the circuit counts **down** at each clock rising edge. Use a switch for the input **U** and another switch for the clock. Note that pins CLR and PR are always high to activate the chip.

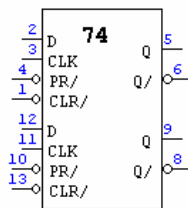

D-type flip-flop

Show all your design steps in the space below:

(2) Simulate your counter design using LogicWorks software and show your simulation to the lab assistant.

Lab assistant: _____

(3) Implement your counter using ICs and demonstrate its working to the lab assistant.

Lab assistant: _____

(4) In your counter implementation, replace the switch connected to the clock by a real clock. Use a function generator and adjust the frequency to 2 Hz. Demonstrate working of your counter to the lab assistant.

Lab assistant: _____

(5) Using 74169 (4-bit up-down counter), build a circuit that counts from 0 to F. Display your output on a hex-seven-segment display. Pin 1 controls the counting sequence (Logic 0: count-down, Logic 1: count-up). Connect the clock input and D1, D2, D3, D4 inputs to switches.

Lab assistant: _____

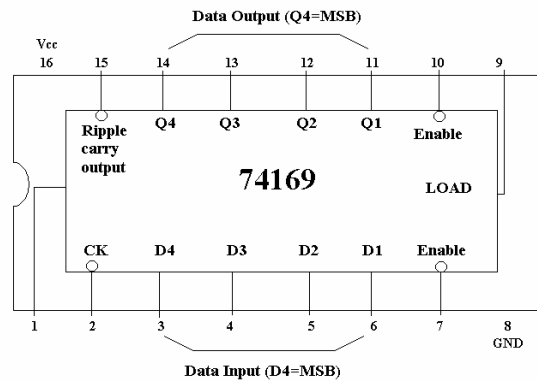

(6) In your 4-bit up-down counter implementation, replace the switch connected to the clock by a real clock. Use a function generator and adjust the frequency to 2 Hz. Demonstrate working of your counter to the lab assistant.

Lab assistant: _____

(7) Simulate your 4-bit up-down counter design using LogicWorks software and show your simulation to the lab assistant. For the 4-bit counter, use the device (counter-4) from the simulation logic library.

Lab assistant: _____

<=====END OF EXPERIMENT NO. 6=====>

APPENDIX

Following are some of the 74xx family ICs commonly used in Digital Logic Design Lab.

